

TWH 200 E and TWH 300 E:

Thermodynamic water heater on ambient air or on outside air with electrical resistance

TWH 300 EH:

Thermodynamic water heater on ambient air or on outside air with heat exchanger for connecting to a boiler or solar, and electrical resistance



TWH 200 E



TWH 300 E,
TWH 300 EH



Domestic hot water



Thermodynamic module
air/water



Electricity
(energy supplied
to the compressor)



Natural renewable energy
free of charges



TWH floor-standing thermodynamic storage water heaters can be connected to the ambient air or the outside air down to -5°C .

They enable domestic hot water to be heated up to 65°C and are therefore perfectly suitable for the replacement of an electric water heater.

The TWH 200 E and 300 E models are fitted with a 2.4 kW safety resistor. The TWH 300 EH models are also fitted with a 2.4 kW electrical safety resistor and an additional exchanger for hydraulic back-up by boiler or solar system.

They comprise principally:

- Enamelled tank, protection by impressed current anode
- Rotary compressor
- Evaporator made of copper pipes and aluminium vanes
- Aluminium condenser fitted around the tank
- Specific regulator for a DHW application, including programming various operating modes, auxiliary heating management, the anti-legionella function, the antifreeze mode, automatic defrosting (see page 3).
- Very thick insulation (0% CFC)

CONDITIONS OF USE

Max operating temp.: - tank: 90°C
- exchanger (TWH 300 EH): 90°C

Max operating pressure: - tank: 10 bar
- exchanger (TWH 300 EH): 10 bar

Air temperature for heat pump functioning: - 5 to $+35^{\circ}\text{C}$

INSTALLING REQUIREMENTS

Room temperature conditions: $+7$ to $+35^{\circ}\text{C}$

Frost-free room

MODELS AVAILABLE

Thermodynamic water heater	Model	Capacity (l)	Heat pump output (kW)	
 <p>With heat pump on ambient or outside air for domestic hot water until 65°C.</p>	With electrical safety resistance	TWH 200 E	215	1.7
		TWH 300 E	270	1.7
	With electrical safety resistance and heat exchanger for connecting to a boiler or solar	TWH 300 EH	265	1.7

TECHNICAL SPECIFICATIONS

MAIN DIMENSIONS (MM AND INCHES)

TWH 200 E** - TWH 300 E

TWH 300 EH

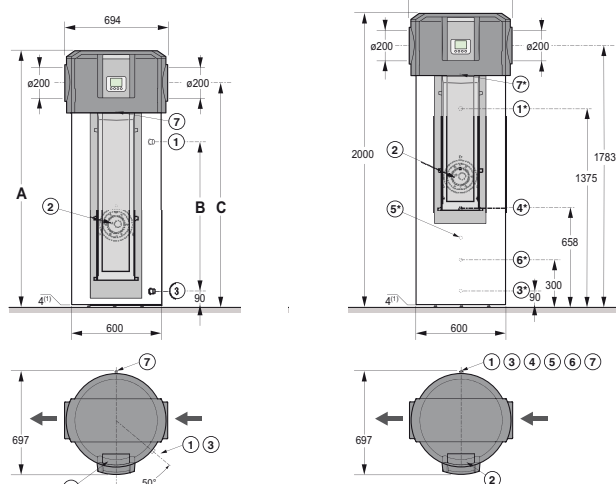

TWH	200 E	300 E
A (mm)	1 690	2 000
B (mm)	974	1 287
C (mm)	1 473	1 783

- ① DHW outlet (without or with dielectric connector) G 3/4"
 - ② Electrical resistance
 - ③ DCW inlet (without or with dielectric connector) G 3/4"
 - ④ Hydraulic exchanger inlet G 3/4"
 - ⑤ Sensor tube for exchanger sensor Ø16mm
 - ⑥ Hydraulic exchanger outlet G 3/4"
 - ⑦ Condensates evacuation tube PVC Ø16 x 12mm
- * Connection at the back
** Model represented

COMPONENTS

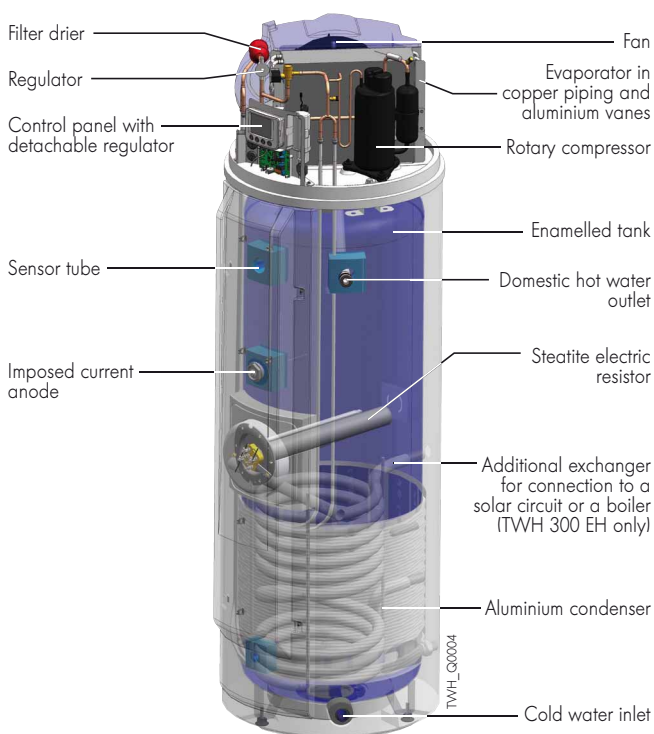

TECHNICAL SPECIFICATIONS

Max operating temp.:
- tank: 90°C
- exchanger (TWH 300 EH): 90°C

Max operating pressure:
- tank: 10 bar
- exchanger (TWH 300 EH): 10 bar

Air temperature for heat pump:
functioning: - 5 to + 35°C
Room temperature: +7 to +35°C

Model	TWH	200 E	300 E	300 EH
Capacity	l	215	270	265
Heat pump output	W	1700	1700	1700
Absorbed electrical power by the heat pump	We	500	500	500
COP (1)		2.9	2.94	2.75
Electrical resistance output	W	2400	2400	2400
Power supply voltage/ Circuit breaker	V/A	230 V Mono/16	230 V Mono/16	230 V Mono/16
Exchanger surface of TWH 300 EH	m ²	-	-	1
Quantity of DHW provided (1)	l	281.9	388	383
Power consumption in establish operating mode (1)	W	30	34	36
Flow per hour at ΔT=35 K (2) (3)	l/h	-	-	955.6
Flow over 10 min at ΔT=20 K (2)	l/10 min.	-	-	420.0
Declared load profile (1)		L	XL	XL
Water heating energy efficiency (4)	%	129	135	132
Heating time (1)	h	7h 48	10h 44	10h 47
Air flow rate	m ³ /h	385	385	385
Available air pressure	Pa	50	50	50
Maximum length of the Ø160 mm air connection	m	25	25	25
Refrigerant R 134 A	kg	1.45	1.45	1.45
Sound pressure*	dB(A)	35.2	35.2	35.2
Weight empty	kg	92	105	123

* at 2 m from the appliance, configuration with sleeve.

(1) Value for water heating from 10 to ≥ 52.5°C with air inlet temperature of 7°C according to EN 16147. (2) Cold water temp.: 10°C, primary hot water: 80°C (3) Output: 34.1 kW (4) According to commission regulation (EU) n° 812/2013 from 18/02/2013.

THE CONTROL PANEL

PRESENTATION OF THE CONTROL PANEL

The control panel fitted to TWH thermodynamic water heaters consists of an easy to use, intuitive, programmable control system, which is also detachable to be wall-mounted in the desired place. It is used to select various operating modes (Automatic, Eco, Boost and Holidays). Domestic hot water production can be further optimised thanks to the off peak/peak hours contact or via suitable timer programming: three adjustable DHW comfort periods per day can therefore be

programmed. The control system can also be used to regulate the desired volume of domestic hot water with management of the tank heating mode (visualised on the display unit): by the HP module, the electric resistor, the hydraulic back-up (TWH 300 EH model) or the various modes combined. It also incorporates a time metering function as well as other functions such as antifreeze protection, anti-legionella, automatic defrosting.

Display

generously sized with simple, intuitive display of the operating modes, timer programming, water quantity or number of baths available, etc.

Navigation keys

and parameter settings with + or -

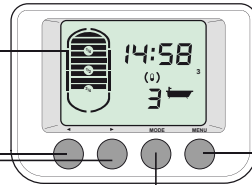

«Menu» key

- Access to the settings (time/date/programme)
- The meters and other parameters
- And the error history or **Reset key**

Setting the operating mode

- **Automatic:** «DHW comfort» programme enabled, DHW production is handled by the HP module and the electric back-up, if necessary (plus hydraulic back-up for TWH 300 EH)
- **Eco:** «reduced» programme enabled, DHW production is handled only by the HP module
- **Boost:** forced operation, DHW production is handled simultaneously by the HP module and the electric back-up (and the hydraulic back-up, where applicable) for a period of 3 hours modifiable)
- **Holidays:** no DHW production for a programmable period; the DHW temperature is nonetheless kept at +10°C to guarantee antifreeze protection or **Validation key**

OPTIONAL EQUIPMENT

EH205



Adapter sleeve Ø 200 on 160mm - Package EH205
90° elbow Ø 160mm - Package EH77

EH77



EH206



Insulated flexible duct Ø 160mm, length 3 m - Package EH206

EH207



Set of fixing clamps Ø 160mm - Package EH207

EH208



Passages through walls Ø 160mm - Package EH208

EH209



Outside grate Ø 160mm (aluminium) - Package EH209

EH558

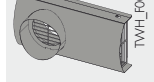

Outside grate with air intake and air discharge Ø 160 mm - Package EH558
Can be mounted horizontally or vertically.
See example of vertical installation page 4

EH272



2 x PPE ducts, Ø 160mm 1 m (delivered with 2 sleeves) - Package EH272



2 x PPE elbows, Ø 160mm (delivered with 2 sleeves) - Package EH273



Vertical terminal (black) Ø 160mm - Package EH275



Water highness bed plate (Ø 160mm) for flat roof - Package EH276



Water highness bed plate (Ø 160mm) for slope of 25 to 45° - Package EH277



Adaptation set - Package EH434

Allows the air connection on the top of the TWH. Compact solution when the TWH is sheathed and installed in a cupboard for example.

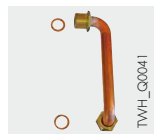

Hydraulic connection for safety kit - Package ER208

Can raise the cold water inlet of the TWH to mount a safety device



2 x PPE sleeves, Ø 160mm - Package EH274



Created by De Dietrich, the **ECO-SOLUTIONS** label guarantees you a range of products compliant with the European Eco-design and Energy Labelling directives. These directives apply from 26 September 2015 to heating and domestic hot water appliances.

With De Dietrich **ECO-SOLUTIONS**, you can benefit from the latest generation of multi-energy systems, easier to use, with better performance and energy savings, designed to give you greater comfort while caring for the environment. **ECO-SOLUTIONS** also mean expertise, advice and a wide range of services from the De Dietrich professional network.

The energy label, together with the **ECO-SOLUTIONS**, shows you the performance of your chosen product. More info at www.dedietrich-heating.com

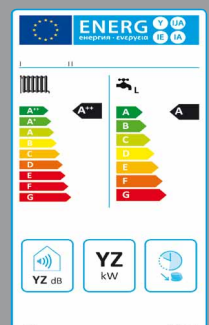

INFORMATION REQUIRED FOR INSTALLATION

INSTALLING

To ensure sufficient air renewal, the minimum volume of the room must be 30m^3 .

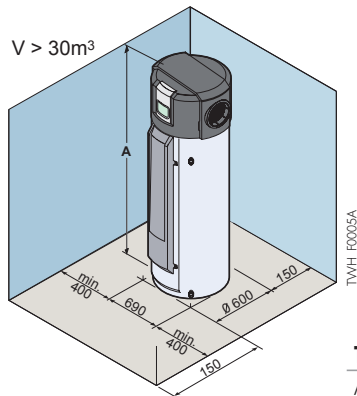

TWH	200 E	300 E	300 EH
A (mm)	1 690	2 000	2 000

Examples of installations:

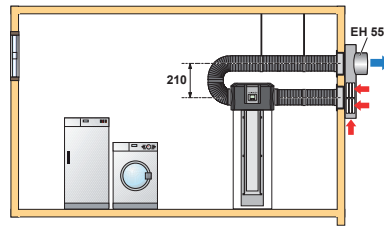

Connection to the outside air

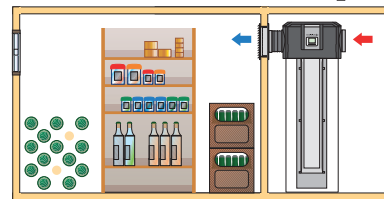

In a cellar (unheated room): can be used to recover calories from the room and keep products cool, for example.

TWH_F0009A

ELECTRICAL CONNECTION

TWH thermodynamic water heaters are delivered with one 230 V/50 Hz power cable. The electrical connection must be in compliance with the NFC 15.100 standard. The water heater must be powered by an electrical circuit comprising an omnipolar switch with an opening gap $> 3\text{mm}$, protected by a 16 A circuit breaker.

The TWH is fitted with a «Peak Hours/Off Peak Hours» contact, allowing it to be installed as a replacement for an existing electric water heater without having to modify the installation. Connection of this contact also makes it possible not to enable operation of the HP module and the electric back-up during peak hours (to give priority to heating by hydraulic solar back-up, for example, on the TWH 300 EH models).

HYDRAULIC CONNECTION

TWH 200 E for DHW preheating, combined with a wall-heating boiler for back-up and instant hot water production.

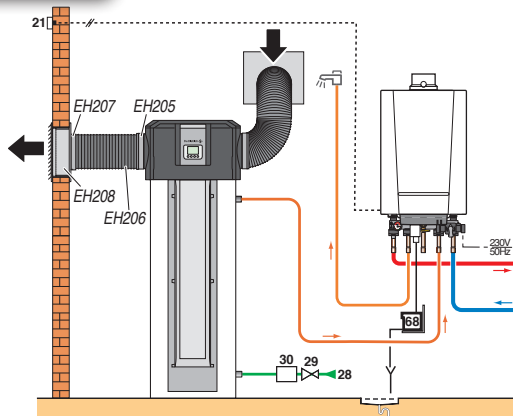

TWH_F0044A

Key

- | | |
|------------------------------|---|
| 3 Safety valve 3 bar | 30 Sealed safety device calibrated to 7 bar |
| 4 Pressure gauge | 33 Domestic hot water temperature sensor |
| 7 Automatic air vent | 57 Domestic hot water outlet |
| 9 Isolation valve | 61 Thermometer |
| 11 Electronic heating pump | 79 Primary outlet of heat exchanger |
| 16 Expansion tank | 80 Primary inlet of heat exchanger |
| 17 Drainage valve | 86 Flow control |
| 21 Outside sensor | 87 Safety valve sealed and calibrated to 6 bars |
| 26 Domestic water load pump | |
| 27 Non-return valve | |
| 28 Domestic cold water inlet | |
| 29 Pressure reducer | |

TWH 300 EH with hydraulic solar back-up

Coupling with solar collectors (collector surface areas between 3 and 5m² are suitable) makes it possible to meet basic DHW needs during the day; additional needs up to 65°C can then be provided by the HP module.

Coupling with a boiler can provide additional comfort if DHW needs are temporarily higher.

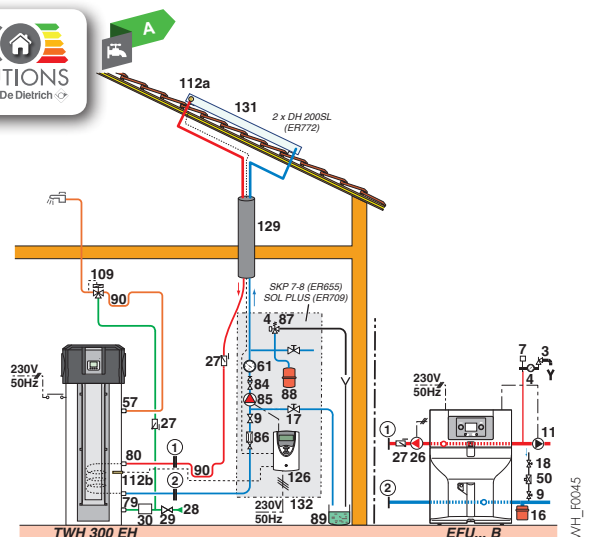

- 88 Solar circuit expansion vessel
- 89 Container to solar fluid
- 90 Antithermosiphon loop
- 109 Thermostatic mixer tap
- 112a Solar collector sensor
- 112b Solar DHW tank sensor

- 114 Primary solar circuit filling and draining circuit
- 126 Solar regulator
- 129 Duo-pipes
- 131 Collector field
- 132 Complete solar station with control unit

TWH_F0045

DE DIETRICH THERMIQUE

S.A.S. with corporate capital of 22 487 610 €
 57, rue de la Gare - F-67580 MERTZWILLER
 Tel. +33 3 88 80 27 00 - Fax +33 3 88 80 27 99
 www.dedietrich-heating.com

